

SWING SIGNS PAVEMENT SIGNAGE

PAVEMENT SIGNAGE



Functional and practical

Easy to assemble

Heavy duty recycled PVC bases

PAVEMENT SIGNAGE

SWING SIGNS

OUR NEW COLLECTION OF PAVEMENT SIGNS ARE FUNCTIONAL, PRACTICAL AND EASY TO ASSEMBLE. THE 'SWING' RANGE OFFERS FIVE ALTERNATIVES TO DELIVER YOUR CUSTOMERS' MESSAGE TO THE HIGH STREET.

CLASSIC SWING

- Complete with white powder-coated printable aluminium sign blank
- Double-sided
- Secured with durable, tamper proof hanging clips
- Durable framework, powder-coated in white or black
- Heavy duty 'double crescent' shaped recycled PVC base
- Easy assembly, no tools required
- Delivered flat pack



- (1) White frame option
- (2) Durable, tamper proof hanging clips
- (3) Frame secures into base



SWITCH SWING

- Quick and easy graphic change clear magnetic pocket
- Header section suitable for overprinting
- Double-sided
- Houses A2 poster graphic
- Secured with durable, tamper proof hanging clips
- Durable framework, powder-coated in white or black
- Heavy duty 'double crescent' shaped recycled PVC base
- Easy assembly, no tools required
- Delivered flat pack



- (1) White frame option
- (2) Durable, tamper proof hanging clips
- (3) Magnetic poster pocket graphic change facility



MINI SWING

- Complete with white powder-coated printable aluminium sign blank
- Double-sided
- Secured with durable, tamper proof hanging clips
- Durable framework, powder-coated in white or black
- Heavy duty shaped recycled PVC base
- Spanner included for base assembly
- Delivered flat pack



- (1) White frame option
- (2) Durable, tamper proof hanging clips
- (3) Attaching frame to base



SIGN WEDGE

- Friction fit assembly
- Complete with white powder-coated, printable, flexible aluminium sign blank
- Double-sided
- Heavy duty circular recycled PVC base
- Cut-outs in base for easy movement
- No tools required for assembly
- Two height options offered
- Delivered flat pack



- (1) Graphic panel wedges into base
- (2) Hand holes in base for easy movement

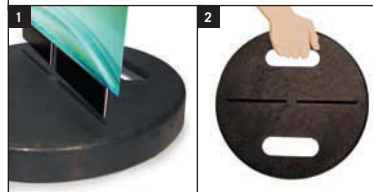

CLASSIC SPECIFICATIONS

Classic - Visual Panel Area

750 x 500mm

SYSTEM SIZES

BOXED SIZE

Classic
935 (H) x 585 (W) x 85 (D) mm
560 (H) x 485 (W) x 120 (D) mm

ASSEMBLED SIZE

Classic
915 (H) x 585 (D) x 475 (D) mm

BOXED WEIGHT

Classic 11.8kg

COMPONENT LIST

Classic

- 1 off recycled PVC base
- 1 off aluminium panel
- 1 off steel frame
- 1 off 4mm allen key

Items attached to steel frame:

- 2 off panel hanging clip
- 4 off screw
- 4 off saddle washer
- 4 off finishing washer

CLASSIC/SWITCH - PANEL ATTACHMENT

- A** Remove screw and fixings from one side of each panel hanging clip using a 4mm allen key.

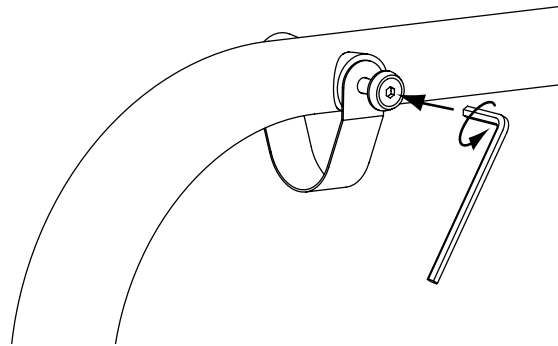

- B** Locate panel onto the panel hanging clips. Reassemble the panel hanging clips using the screws and fixings.

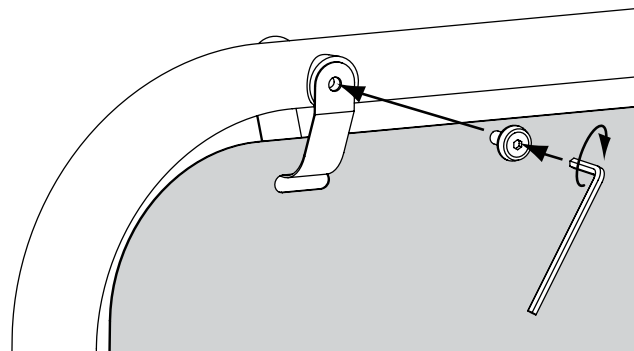

- C** Reassembled panel hanging clip.

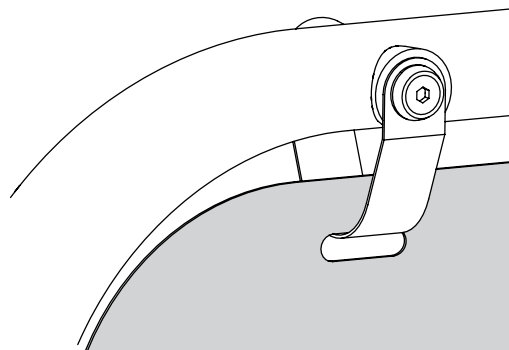

SIGN WITHOUT PANEL

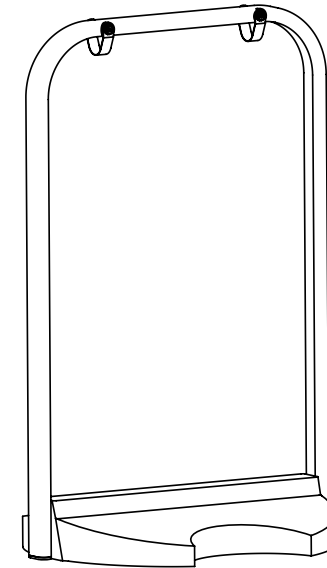

SIGN WITH PANEL ATTACHED

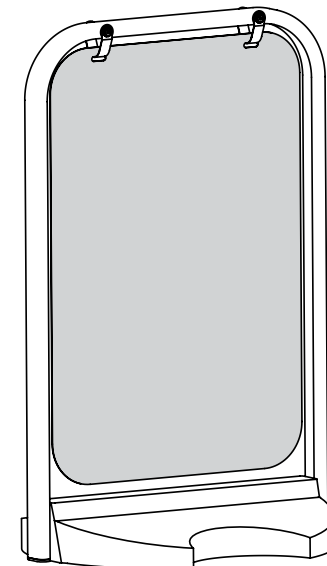

CLASSIC/SWITCH - ASSEMBLY

A

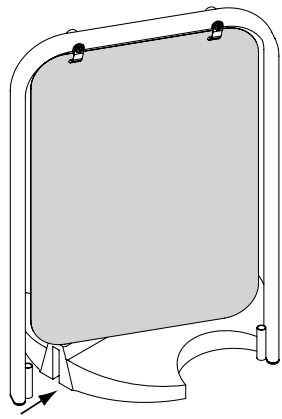

View of the underside

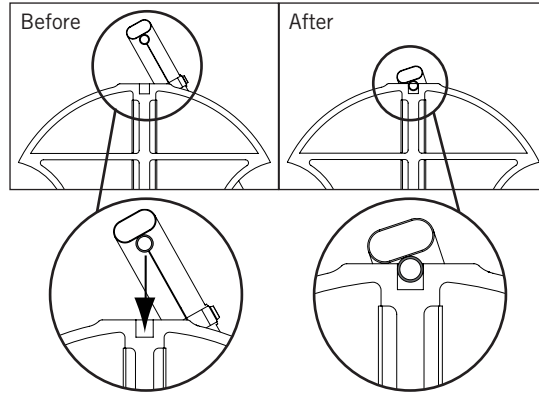

B

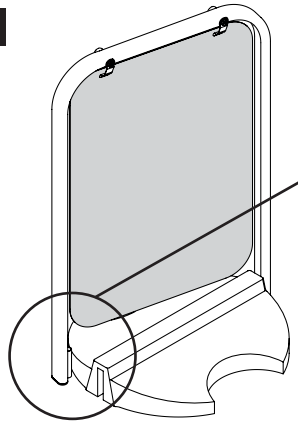

View of the underside

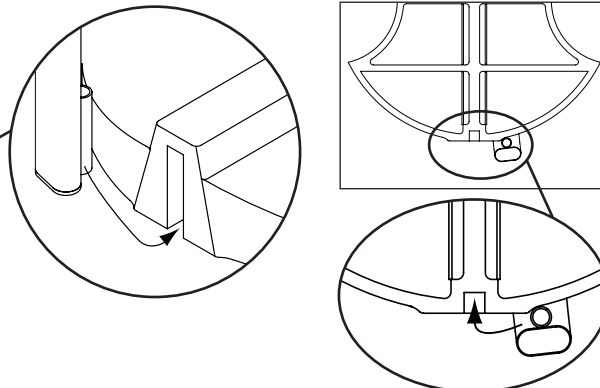

C

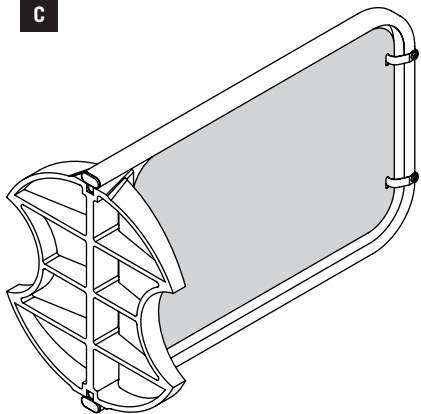

View of the underside

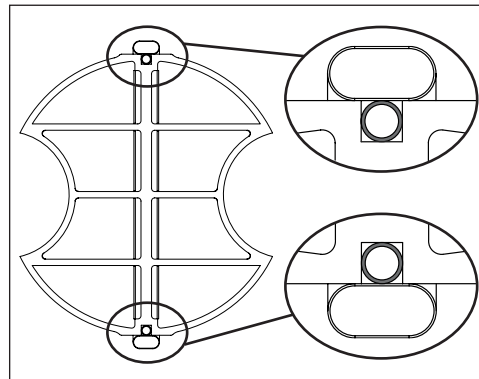

SWITCH - ADDING GRAPHICS

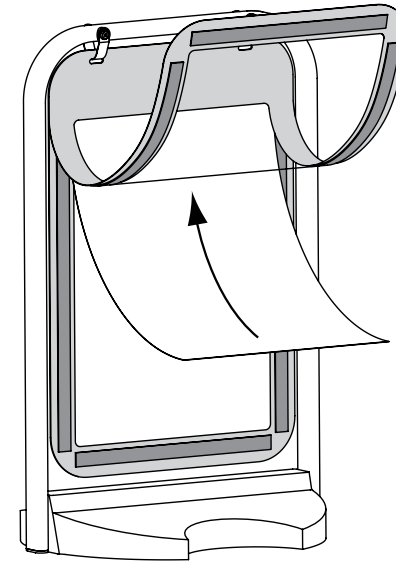

CLASSIC/SWITCH - FULLY ASSEMBLED

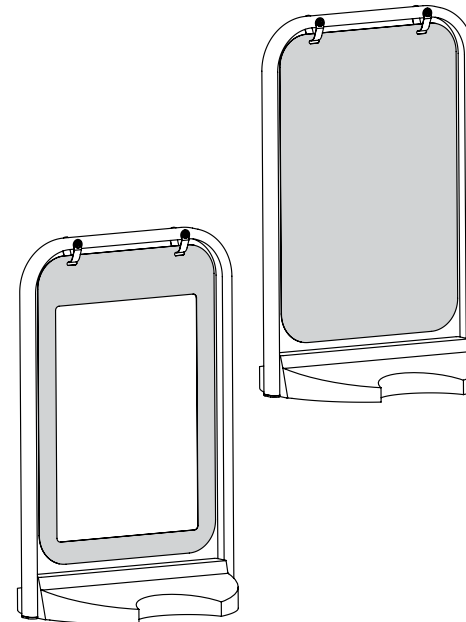

SWITCH SPECIFICATIONS

Switch - Graphic Panel Size

A2 (594 x 420mm)

Switch - Visual Area

574 x 400mm

SYSTEM SIZES

BOXED SIZE

Switch

935 (H) x 585 (W) x 85 (D) mm
560 (H) x 485 (W) x 120 (D) mm

ASSEMBLED SIZE

Switch

915 (H) x 585 (D) x 475 (D) mm

BOXED WEIGHT

Switch 11.8kg

COMPONENT LIST

Switch

- 1 off recycled PVC base
- 1 off flexible pocket
- 1 off steel frame
- 1 off 4mm allen key

Items attached to steel frame:

- 2 off panel hanging clip
- 4 off screw
- 4 off saddle washer
- 4 off finishing washer

SPECIFICATIONS

VISUAL PANEL AREA

600 x 400mm

SYSTEM SIZES

BOXED SIZE

775 (L) x 495 (W) x 60 (D) mm
420 (L) x 400 (W) x 95 (D) mm

ASSEMBLED SIZE

760 (H) x 490 (D) x 390 (D) mm

BOXED WEIGHT

7.6kg

COMPONENT LIST

- 1 off recycled PVC base
- 1 off aluminium panel
- 1 off steel frame
- 1 off washer
- 1 off spring washer
- 1 off nut
- 1 off spanner
- 1 off 4mm allen key

Items attached to steel frame:

- 2 off panel hanging clip
- 4 off saddle washer
- 4 off finishing washer
- 4 of screw

MINI SWING - PANEL ATTACHMENT

- 1 Remove screw and fixings from one side of each panel hanging clip using a 4mm allen key.

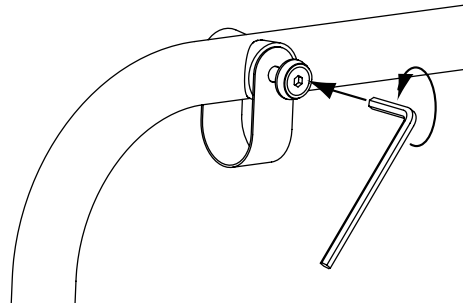

- 2 Locate panel onto the panel hanging clips. Reassemble the panel hanging clips using the screws and fixings.

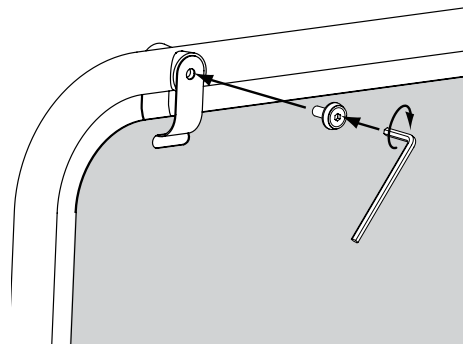

- 3 Reassembled panel hanging clip.

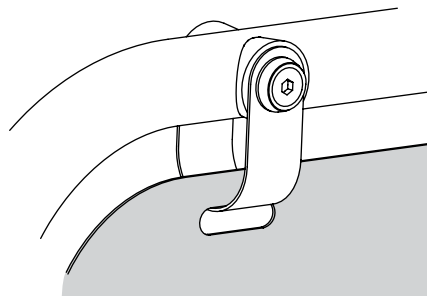

MINI SWING - ASSEMBLY

- 1 Assemble using spanner provided.

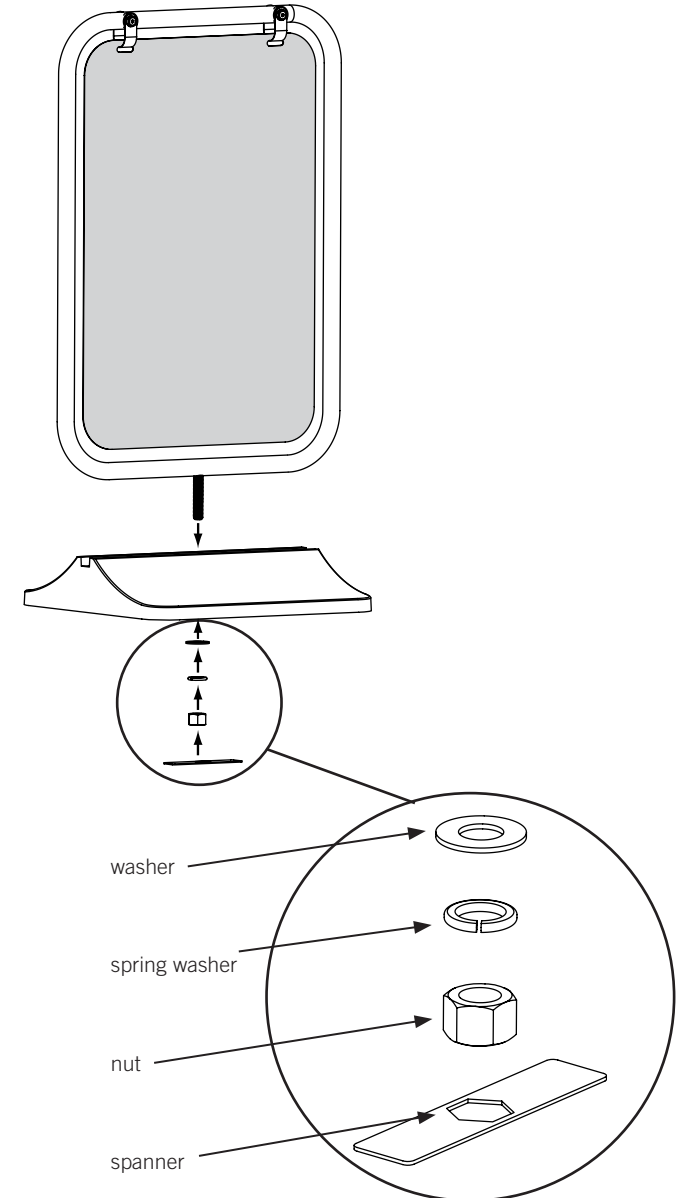

SPECIFICATIONS

VISUAL PANEL AREA

Large

740 x 410mm

Small

585 x 390mm

SYSTEM SIZES

BOXED SIZE

Large

450 (L) x 430 (W) x 70 (D) mm

905 (L) x 435 (W) x 10 (D) mm

Small

450 (L) x 430 (W) x 70 (D) mm

770 (L) x 485 (W) x 10 (D) mm

ASSEMBLED SIZE

Large

790 (H) x 420 (D) x 420 (D) mm

Small

635 (H) x 420 (D) x 420 (D) mm

BOXED WEIGHT

Large 6.8kg

Small 6.5kg

COMPONENT LIST

1 off recycled PVC base

1 off aluminium panel

4 off plastic wedge

SIGN WEDGE - LARGE/SMALL PANEL PREPARATION

Stick wedges to panel.
Ensure wedges are
positioned correctly
with the thin end of the
wedge at the bottom.

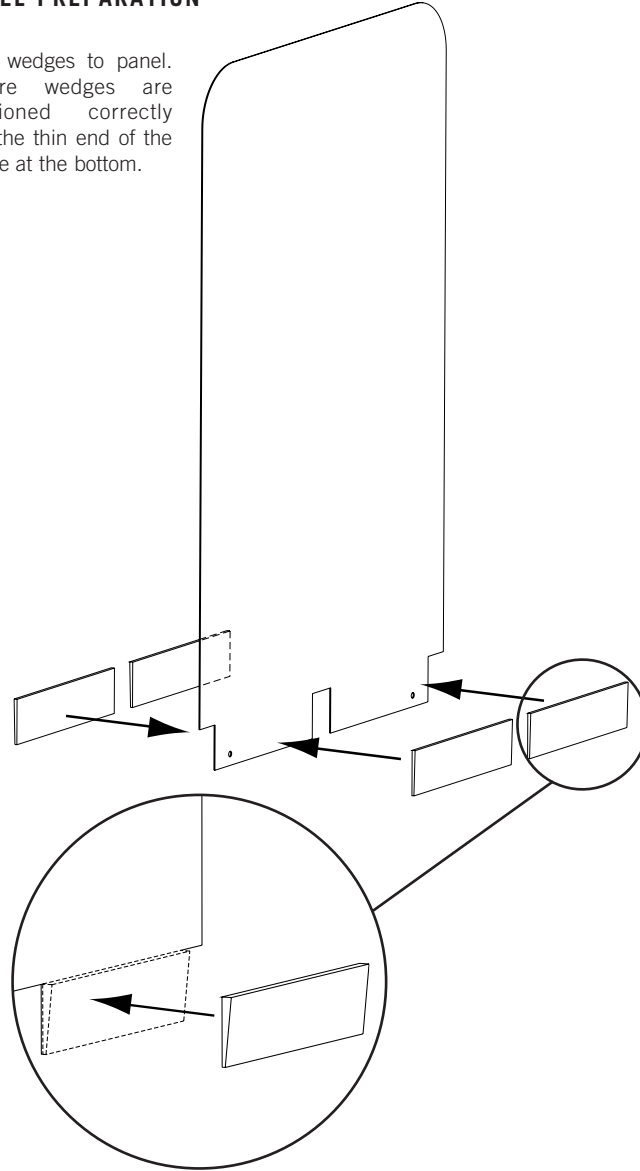

IMPORTANT NOTICE:

- Apply pressure to wedges to ensure a firm bond between panel and wedges.
- Allow adhesive to cure for 24 hours before using this product.

SIGN WEDGE - LARGE/SMALL ASSEMBLY

- 1 Wedge panel into base.

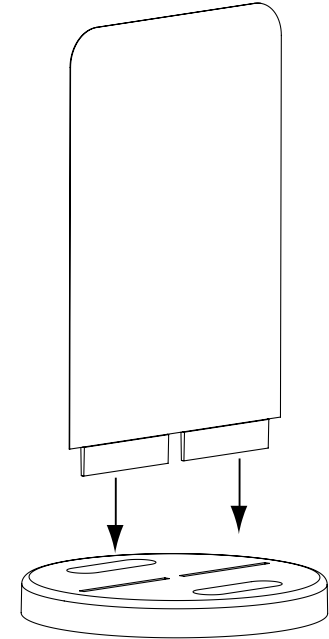

- 2 Finished unit.

